

Estimation of Maximum Damping Force and Bending Stress of Suspension Components Using the AutoDyn7 Program

Wan-Suk Yoo*, Myung-Gyu Kim**, Jeong-Woo Lee**, Kwang-Suk Kim***
and Sang-Yoon Shin****

(Received October 7, 1998)

In this paper, stresses at the suspension components are calculated using the joint reaction forces obtained from computer simulation. The Shear Force Diagram, Bending Moment Diagram, and the stress distribution of the damper strut are also calculated. The AutoDyn7 program is used for the computer simulation, which is a vehicle dynamics program developed in G7 project.

Key Words: AutoDyn7 Program, Suspension component, Bending Stress, Damping Force

1. Introduction

For the vehicle dynamic analysis, DADS and ADAMS programs are widely used in Korean industries. Since these programs are well developed as a general purpose multibody dynamics program, it is very useful in the sense of dynamic analysis of automobiles. The users, however, are confined to modify some parts of the program for their own purpose.

Progressing toward one of major car manufacturers, the Korean automobile industry needs to develop its own technologies. Among these technologies, an original vehicle dynamic code appeared as one of key technologies. The industries require not only an original program to modify easily for their individual purpose, but also advanced modules and facilities for convenient simulation. The AutoDyn7 program, a research product supported by the Korean automobile industries, has several useful user-friendly subroutines. Furthermore, it has an input translator to convert the DADS input or ADAMS input to an AutoDyn7 input (Kim et al., 1995).

In this paper, the general structure and main algorithm of the AutoDyn7 program are briefly explained. Using the suspension module, road module, roll stabilizer module, and tire module of the AutoDyn7 program, a multibody model of a passenger car is generated. From the computer simulation using the AutoDyn7 program, the reaction forces at the suspension components are calculated. Furthermore, the Shear Force Diagram, Bending Moment Diagram, and the stress distribution of the damper strut are calculated.

2. Vehicle Modeling Using AutoDyn7 Program

2.1 AutoDyn7 program

2.1.1 General structure (Kim et al., 1995)

AutoDyn7 program is composed of (1) Pre-Processor (2) IP (Intermediate Processor) (3) Main Program (4) Post-Processor. In the pre-processor, data input and graphic representation of the system is contained. The IP is used to combine finite element programs for the flexible structure analysis. The main routine assembles the system, generates the equations of motion, and provides the solution. The post-processor generates the graphic output and animation. It also includes the PSD (Power Spectral Density) calculation for a frequency analysis of the dynamic output.

* Professor, Mechanical Engineering, Pusan National University

** Graduate School, Mechanical Engineering, Pusan National University

*** Automobile Eng., Andong Science College

**** Daewoo Precision Industries LTD

2.1.2 Equations of Motion

The equations of motion of the AutoDyn7 program are derived using a velocity transformation technique (Jerkovsky, 1978; Kim and Vanderploeg, 1984; Lee et al., 1993). The velocity transformation combines the generality of the Cartesian coordinates and the efficiency of the joint coordinates. The constraint equations generated by a cut joint are derived in the Cartesian coordinates, and transformed to a joint space. The Jacobian matrix of the constraint equation is also derived in the Cartesian space and then transformed to the joint space. The final equations of motion of the system are written as;

$$\begin{bmatrix} \bar{M} & \Phi_q^T \\ \Phi_q & 0 \end{bmatrix} \begin{bmatrix} \ddot{q} \\ \lambda \end{bmatrix} = \begin{bmatrix} \bar{g} \\ \gamma \end{bmatrix} \quad (1)$$

where $\bar{M} = B^T M B$ is a generalized mass matrix, B is a velocity transformation matrix, $\bar{g} = B^T [f - M\ddot{B}q - \dot{M}B\dot{q}]$ is a generalized force vector, and λ is a Lagrange multiplier vector.

Since the Eq. (1) is a DAE (Differential Algebraic Equation), a coordinate partitioning scheme (Wehage and Haug, 1982) or a constraint stabilization scheme (Baumgarte, 1989) is employed to solve it.

2.2 Special modules in AutoDyn7

2.2.1 Road module

The road module, in AutoDyn7 program, calculates the spatial road roughness data using the PSD data supplied from a user. Furthermore, several useful road grades defined by ISO and MIRA are already stored as database, which enables to generate road profile just specifying "ISO grade A" or "ISO grade B". The Belgian road profile is also stored in the road module, and attached to a vehicle simulation by specifying "Belgian".

2.3.2 Tire module

The tire module in the AutoDyn7 program has several options for users. The Carpet plot option is used to input the experimental data from the user. The DADS tire option offers the same function as three kinds of DADS tire model (Basic, Intermediate, Full). The UA tire model in AutoDyn7 has the same function as ADAMS UA

tire. The STI (Mohamed, 1996) tire model is also implemented in the AutoDyn7.

2.2.3 RSB (roll stabilizer bar) module

To model a roll stabilizer bar in the suspensions, the RSB module in the AutoDyn7 program offers three modeling options. The simplest modeling is to install a rotational spring at the midpoint of the bar, which transfers the force between the right wheel and left wheel. In the rotational spring model, only the deflection due to twisting moment is considered to calculate the stiffness of the roll bar. The second model of RSB considers deflections due to twisting moment and bending moment. The third model uses the finite element technique to calculate the stiffness of the RSB. The second model, which combines the twisting and bending moment, is recommended due to simplicity and reliability.

2.3 Vehicle modeling using AutoDyn7

2.3.1 Suspension modeling

The suspension templates in the preprocessor of the AutoDyn7 program are very useful for a suspension modeling. Users are only required to specify the locations of joints in the suspension. Then, the program calculates the joint axes and path matrices (Jerkovsky, 1978) of the suspension system. There is another option for the suspension modeling, in which the joint data are supplied by the user. In this paper, the input data associated with joint types are converted from the DADS input. In Figs. 1 and 2, the front and the rear suspensions are shown.

2.3.2 Modeling of damper strut

A damper is one of the most important components of a suspension system that determines dynamic response of a vehicle. In this paper, a strut typed damper is used. An upper mount of the piston rod is connected to a chassis through a strut mount. A lower mount of outer tube is welded to a knuckle. A coil spring around outer tube is attached to chassis.

2.3.3 Full car modeling

With prescribed suspension and damper

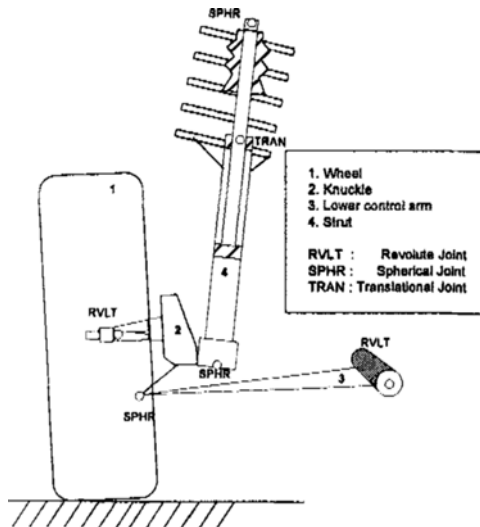

Fig. 1 Front suspension of the vehicle.

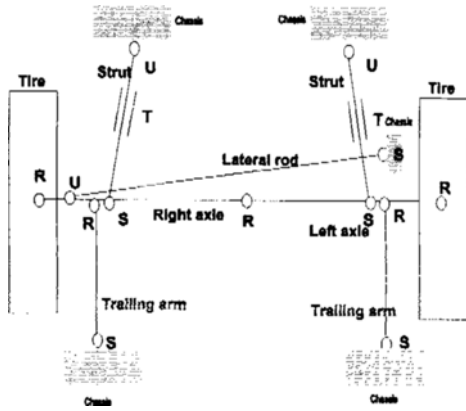

Fig. 2 Rear suspension of the vehicle.

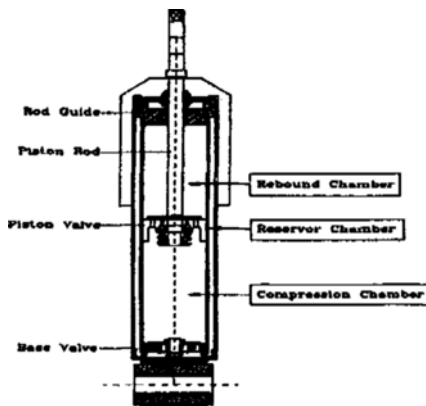

Fig. 3 Structure of twin type oil damper.

models, a full vehicle model is constructed. The properties of the vehicle components are listed in Table 1 and Fig. 4. 15 D. O. F (degree of freedom) vehicle model is used, and basic tire model is employed. Dynamic simulations are carried out with the AutoDyn7 program.

3. AutoDyn7 Simulation

3.1 Reaction forces running over a bump and pothole

Joint reaction forces in the AutoDyn7 program are calculated from constraint reaction forces of the cut joints(Choi et al., 1998).

A vehicle at 30km/hr is simulated over bump and pothole, shown in Fig. 5, to see variation of

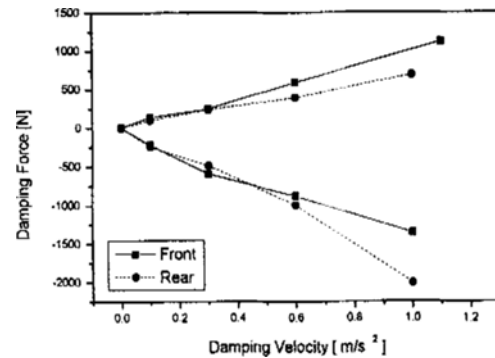

Fig. 4 Characteristics of damping force.

Table 1 Vehicle properties.

Vehicle Mass	1375.9 Kg
Front Suspension Stiffness	20784.84 N/m
Rear Suspension Stiffness	191212.7 N/m
Tire Vertical stiffness	206000 N/m
Tire Vertical Damping Coefficient	2060 N·s/m

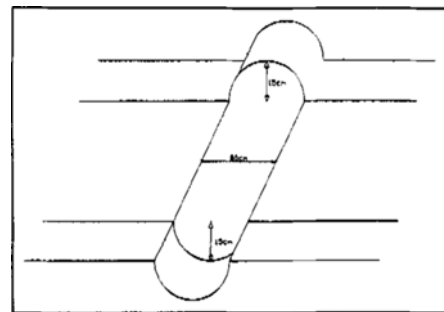

Fig. 5 Bump and pothole.

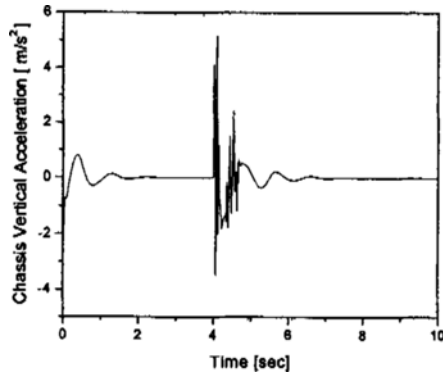

Fig. 6 Chassis Vertical Acceleration(bump and pothole).

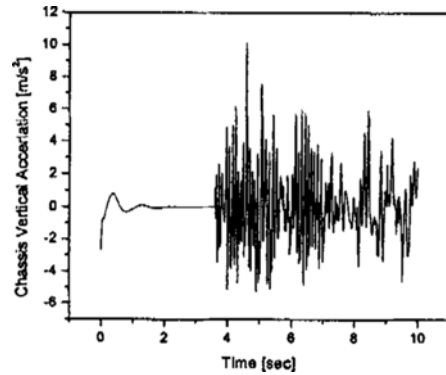
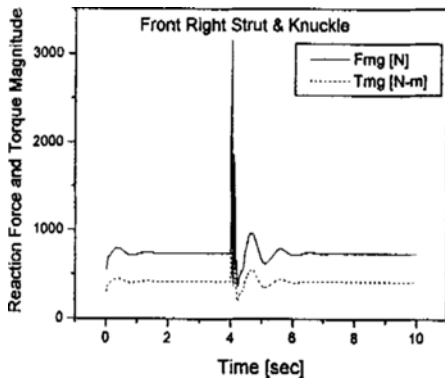

Fig. 8 Chassis Vertical Acceleration(Belgian Road).



(a) Reaction Force and Torque Magnitude (Front Right)

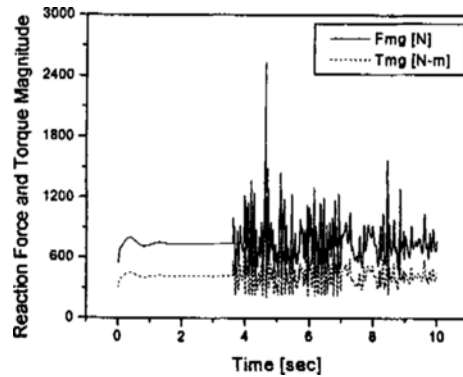
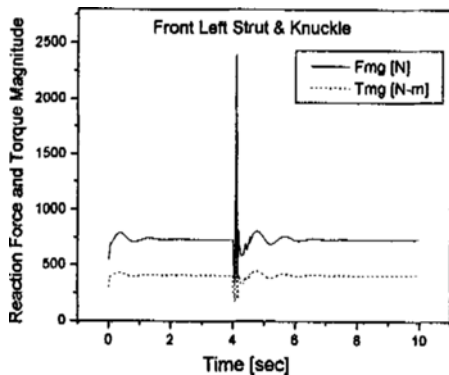

Fig. 9 Reaction Forces and Torques of Translational Joint.



(b) Reaction Force and Torque Magnitude (Front Left)

Fig. 7 Reaction Forces and Torques of Translational Joint.

load acting on damper strut. Length of bump and pothole is 80cm and depth is 15cm. Figure 6 shows the maximum chassis vertical acceleration, which appears to be about 0.5g.

Since a suspension is designed to support vertical and lateral forces, lateral force may act on a damper strut during driving the vehicle. Thus, resultant shear force causes damper strut to be bent and deformed. Reaction forces of the translational joint connecting a knuckle and a damper strut are shown in Fig. 7.

Front right wheel is passed over bump, and front left wheel goes over pothole. Figure 7(a) shows that maximum reaction force and torque on right damper strut passing over bump are 3160N, and 1733N-m respectively. Figure 7(b) shows that maximum reaction force and torque on the left damper strut passing over pothole is 2400N and 1536N-m, respectively.

3.2 Reaction forces running over a Belgian road

A Belgian road is widely used to test durability

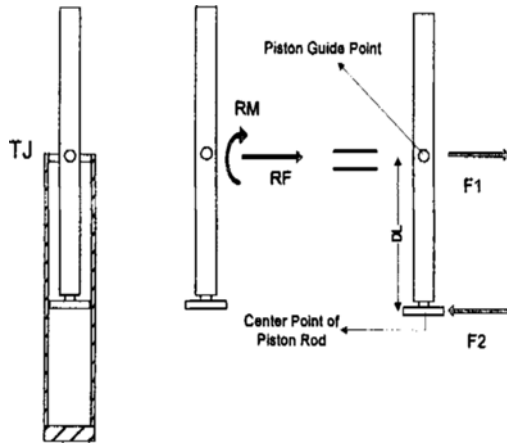
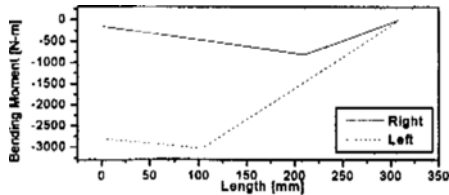
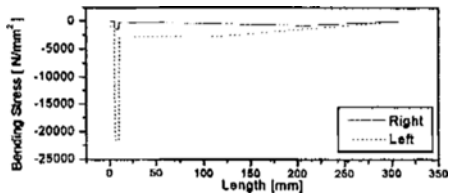

Fig. 10 Equivalent Forces of Torque.



(a) Bending Moment Diagram



(b) Bending Stress Diagram

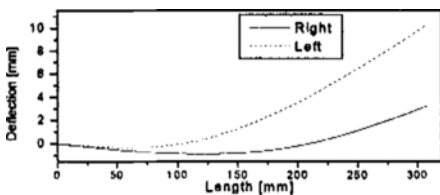

(c) Deflection Line

Fig. 11 Design Factor of Piston Rod

of vehicle components. The belgian road data for the simulation is generated in the road module of the AutoDyn7 program. Figure 8 shows that maximum vertical acceleration of a vehicle is 1.03g moving on the Belgian road at 30km/hr.

Reaction forces running over a belgian road is shown in Fig. 9. The maximum reaction force was

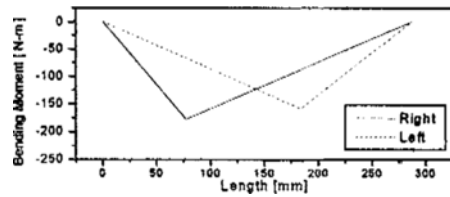

(a) Bending Moment Diagram

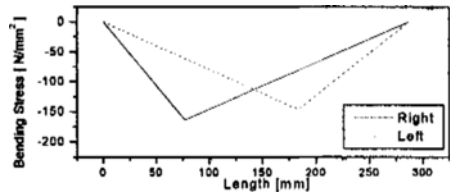

(b) Bending Stress Diagram

Fig. 12 Design Factor of Cylinder Tube

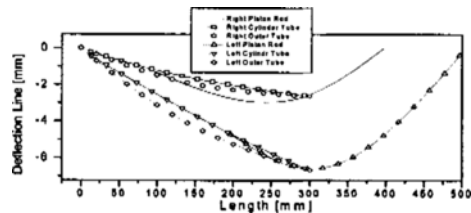

Fig. 13 Total Deflection Line

2532N and torque was 1318N-m. The reaction forces are relatively small compared with those in the bump & pothole simulation. So it can be concluded that the bump & pothole simulation offers severer load condition than the belgian road simulation.

4. Design of a Damper Strut

4.1 Calculation procedure of BMD(bending moment diagram) and bending stress

1) The reaction force RF and reaction torque RM are replaced with a force F2 at the rod guide and a force F1 at the center position of a piston rod as shown in Fig. 10.

2) With forces F1 and F2, applied forces on each part of strut damper (piston rod, cylinder tube, outer tube) are calculated via static analysis (Kim et al., 1998).

3) Assuming the piston rod and the cylinder tube as simply supported beams and outer tube as

a cantilevered beam, bending moment, stress, and deflections of piston rod, cylinder tube, and outer tube are calculated.

4.2 Results of SFD, BMD, and deflection of damper strut

1) Piston rod

Figure 11(a) shows the maximum bending moment applied to the rod guide. Figures 11(b) and (c) show bending stress and deflection line of the piston rod, respectively. We can see that severer deflection is occurred when strut damper is in tension.

2) Cylinder tube

Figures 12(a) (b) show the maximum bending moment and bending stress applied to overlaped part of the piston rod and cylinder tube. The maximum bending moment and the maximum bending stress are $-175.9(\text{N}\cdot\text{m})$, and $-161.96(\text{N}/\text{mm}^2)$, respectively.

3) Deflected Shape of the Damper

Figure 13 shows the total deflection line of the piston rod, cylinder tube, and outer tube. Deflection of the cylinder tube and outer tube is expressed relative to dash-dotted line connected each component edge to see overall deformation under assembly condition. The cylinder tube and outer tube have smaller deformation compared with the piston rod.

5. Conclusion

In this paper, a general procedure to get design data from dynamic simulation is introduced with a suspension damper. The maximum bending stress and deflection lines of damper strut of a vehicle are calculated with vehicle dynamic analysis program, AutoDyn7.

The piston rod is the most deformed among three components of a strut damper. It is shown that stress concentration is occurred at the piston rod guide position. These results can be very useful for design of dampers.

Acknowledgement

This research was supported by GRANT No.

97-0200-1001-5 from the KOSEF (Korea Science and Engineering Foundation)

Reference

- Kim, K. S., Kim, O. J., Choi, T. Y., Yoo, W. S. and Kim, S. S., 1995, "Development of Vehicle Dynamics Program AutoDyn7," *KSAE Autumn Conference Proceeding*, Vol. 1, pp. 267~273.
- Jerkovsky, W., 1978, "The Structure of Multibody Dynamics Equations," *J. Guidance and Control*, Vol. 1, No. 3, pp. 173~182.
- Kim, S. S. and Vanderploeg, M. J., 1985, "A State Space Formulation for Multibody Dynamic Systems subject to Control," Univ. of Iowa, Tech. Report No. 84-20, Dec.
- Lee, B. H., Yoo, W. S and Kwak, B. M., 1993, "A Systematic Formulation for Dynamics of Flexible Multi-body Systems using the Velocity Transformation Technique," *J. of Mechanical Engineering Science*, IMechE, Vol. 207, No. c4, pp. 231-238.
- Wehage, R. A. and Haug, E. J., 1982, "Generalized Coordinate Partitioning of Dimension Reduction in Analysis of Constrained Dynamic Systems," *Trans. of ASME, J Mechanical Design*, Vol. 104, pp. 247~255.
- Baumgarte, J., 1989, "Stabilization of Constraints and Integrals of Motion in Dynamic Systems," *Computer Methods in Applied Mechanics in Engineering*, Vol. 1, 1972, pp. 1~16, pp. 321~327.
- Mohamed Kamel Salaani, Ph. D thesis 1996, "Development and Validation of a Vehicle Model for the National Advanced Driving Simulator," *The Ohio State University*.
- Choi, Y. C., Kim, K. S., Kim, O. J. and Yoo, W. S., 1998, "Analysis of Joint Reaction Forces of Flexible Multibody System with Closed Loops," *Transactions of the KSME*, Vol. 22, No. 3, pp. 704~713.
- Kim, K. S., Kil, H. M. and Yoo, W. S., 1998, "Development of a CAE Technique for Vehicle Suspension Design," *Journal of Korean Society of Precision Engineering*, Vol. 15, No. 1, pp. 160~168.